

Duo-Aire

W-FP Front Face Make-up Air Canopy

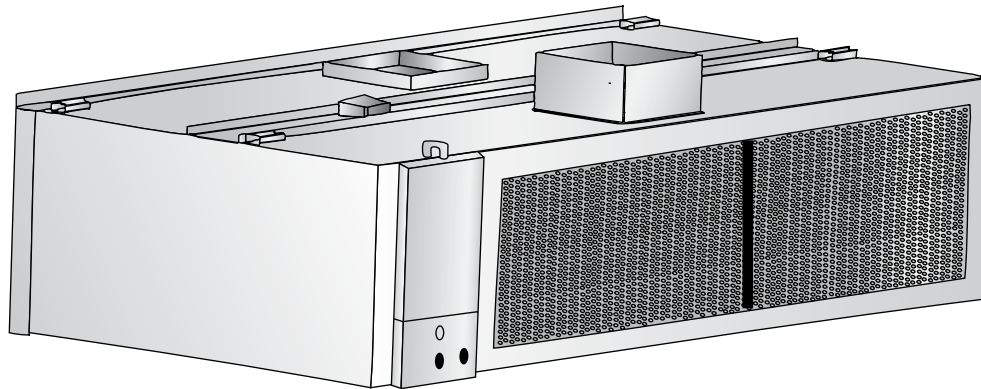

Model W-FP

A single plenum front face discharge make-up air canopy constructed of stainless steel where visible and aluminized steel where concealed. All external seams shall be fluid welded and all internal seams shall be sealed with a high temp. silicone caulk. Supplied with fire damper and air volume damper. Perforated metal is used to diffuse the air and spread an even air flow across the face. Canopy shall be listed to meet NSF and UL standards and constructed to meet NFPA-96. Grease trough to be easily removable and slope to removable grease cup.

STANDARD FEATURES

- UL Listed Aluminum Grease Filters
- UL Listed Globe Lights
- 3" Rear Air Space
- Removable Grease Trough & Cup
- Front Face Double Deflection Aluminum Diffusers
- Exhaust & Supply Collars Installed
- Hanging Brackets
- UL Listed Fire and Air Volume Dampers in Supply Collar
- Surface Mounted Control Panel

OPTIONS

- All Stainless Steel Construction
- UL Listed Stainless Steel Grease Filters
- 14" Utility Cabinet for Fire Suppression System
- Electrical Control Panel
- Pre-Plumbed Fire Suppression
- Stainless Steel Top Enclosures
- UL Listed Insulated Top, Back and/or Ends for Zero Clearance to Combustible

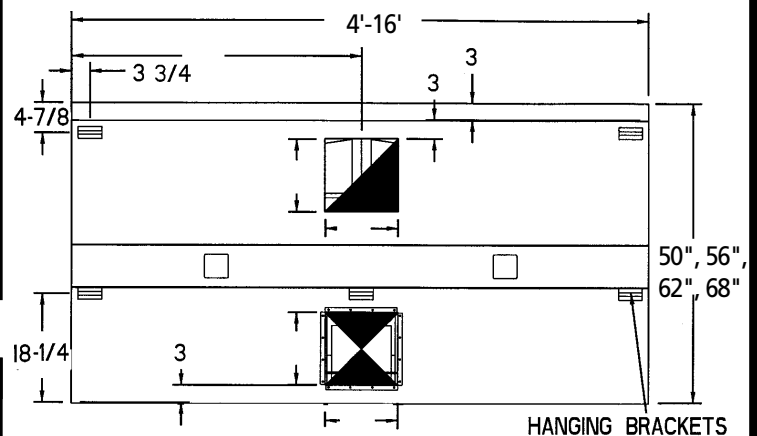

Plan View

(See reverse side for larger drawing)

Note: Two exhaust ducts required after 12' long.

BUILT IN
ACCORDANCE
WITH NFPA 96



W-FP Series - Front Face Make-up Air Canopy

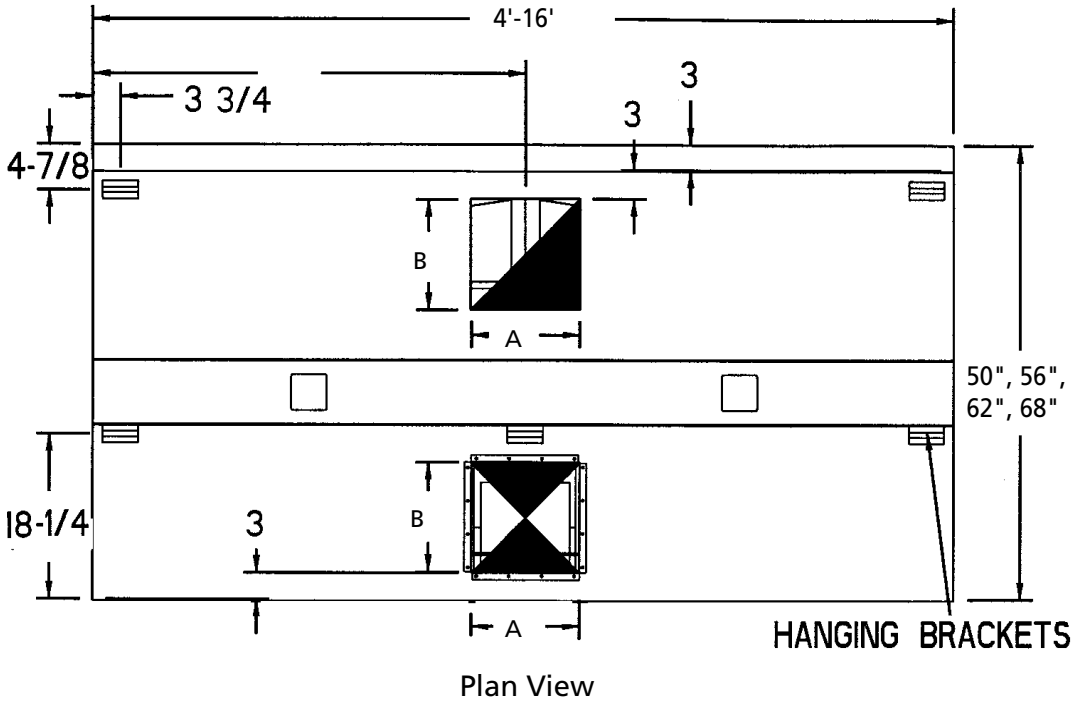

Note: Two exhaust ducts required after 12' long.

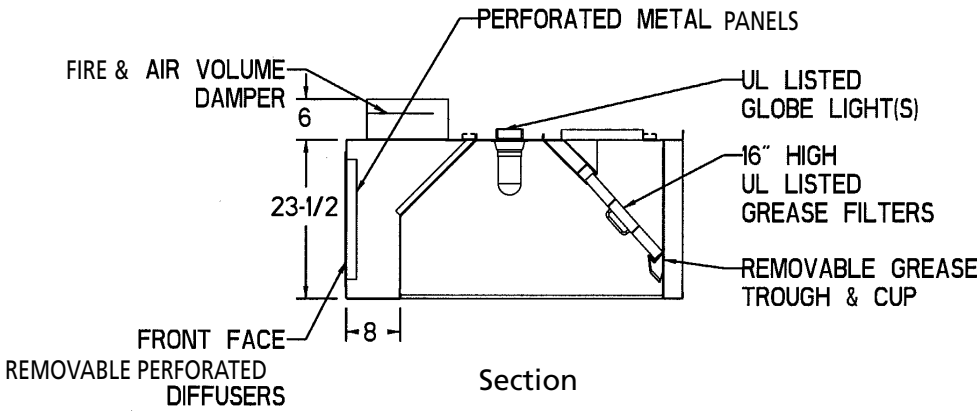

EXHAUST AND SUPPLY RATE REQUIREMENTS

(Recommended Min. Exhaust Flow Rate)	TEMPERATURE OF EQUIPMENT		
	400°	600°	700°
CFM Exhaust / Ft.	275	300	350
CFM Supply / Ft.	220	240	280

ORDER ENTRY INFORMATION

Project:

Item:

Representative:

Model:

Length: Qty:

Width:
Height:

Duct - Concentric
 Parallel

Exhaust CFM:
Supply CFM:

Entered by:

Date:

Drawings Req'd: Y N

List Miscellaneous
Options Separately



Duo-Aire reserves the right to make changes in design and specifications without prior notice.



Duo-Aire

W-FP-AVC Front Face Make-up Air Canopy

With Air Volume Controllers

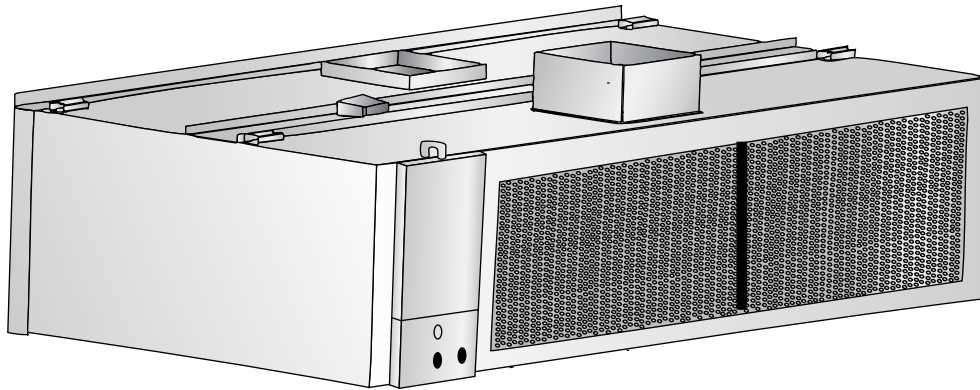

Model W-FP-AVC

A single plenum front face discharge make-up air canopy constructed of stainless steel where visible and aluminized steel where concealed. All external seams shall be fluid welded and all internal seams shall be sealed with a high temp. silicone caulk. Supplied with fire damper and air volume damper. Perforated metal is used to diffuse the air and spread an even air flow across the face. Exhaust canopy to be equipped with stainless steel adjustable Air Volume Controllers installed directly behind the removable grease filters. Air Volume Controllers are to be factory installed and adjusted for the cooking equipment specified. Canopy shall be listed to meet NSF and UL standards and constructed to meet NFPA-96. Grease trough to be easily removable and slope to removable grease cup.

STANDARD FEATURES

- UL Listed Aluminum Grease Filters
- UL Listed Globe Lights
- 3" Rear Air Space
- Removable Grease Trough & Cup
- Exhaust & Supply Collars Installed
- Hanging Brackets
- Stainless Steel Adjustable Air Volume Controllers
- UL Listed Fire and Air Volume Dampers in Supply Collar
- Flush Mounted Control Panel

OPTIONS

- All Stainless Steel Construction
- UL Listed Stainless Steel Grease Filters
- 14" Utility Cabinet for Fire Suppression System
- Electrical Control Panel
- Pre-Plumbed Fire Suppression
- Stainless Steel Top Enclosures
- UL Listed Insulated Top, Back and/or Ends for Zero Clearance to Combustible

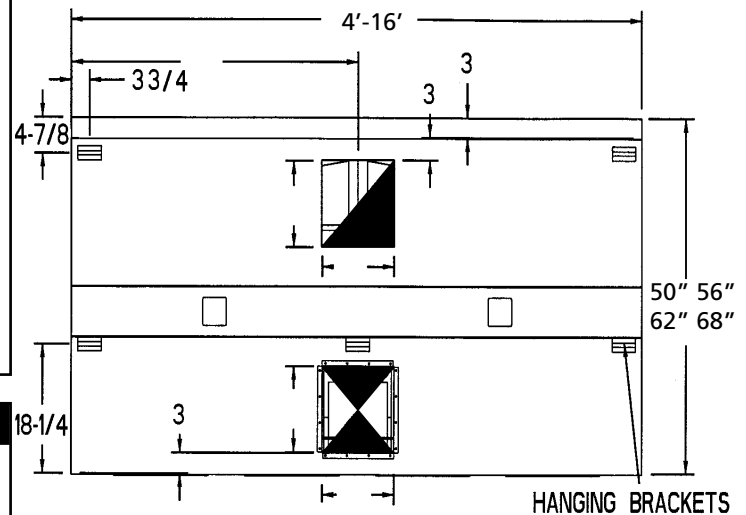

Plan View
(See reverse side for larger drawing)

BUILT IN
ACCORDANCE
WITH NFPA 96



W-FH-AVC Series - Front Face Make-up Air Canopy

W-FP-AVC Series Specifications

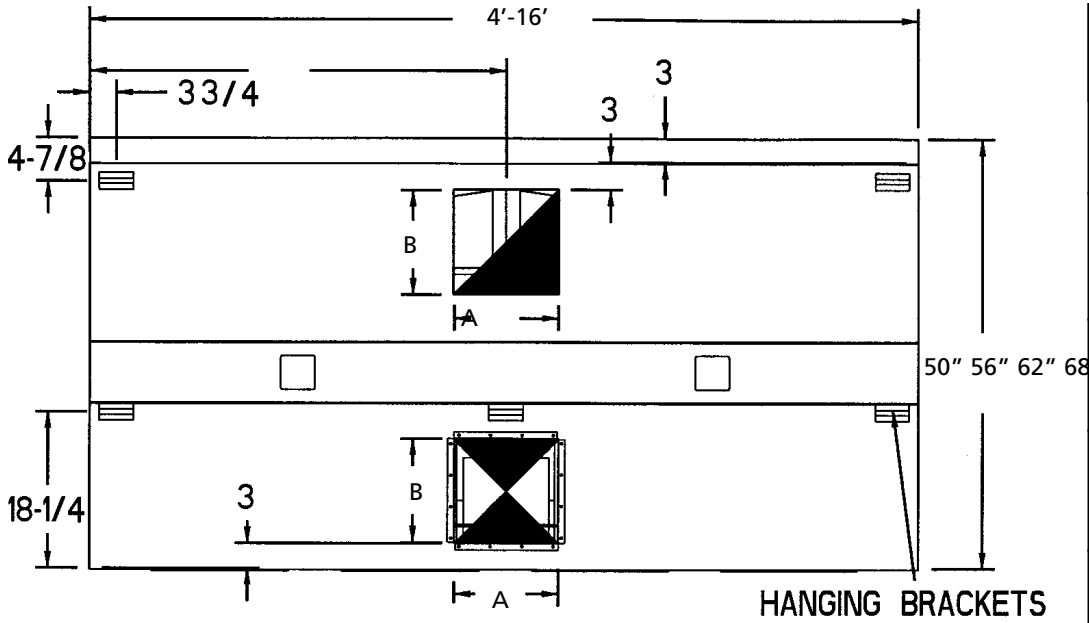

Plan View

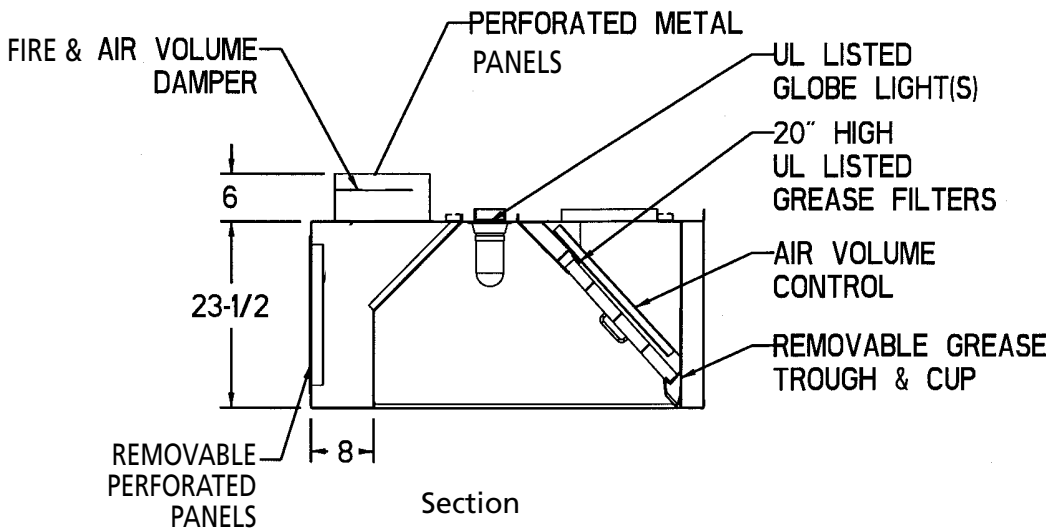

Section

EXHAUST AND SUPPLY RATE REQUIREMENTS

(Recommended Min. Exhaust Flow Rate)	TEMPERATURE OF EQUIPMENT		
	400°	600°	700°
CFM Exhaust / Ft.	200	250	-
CFM Supply / Ft.	160	200	-

ORDER ENTRY INFORMATION

Project:

Item:

Representative:

Model:

Length: Qty:

Width:
Height:

Duct - Concentric
Parallel

Exhaust CFM:
Supply CFM:

Entered by:

Date:

Drawings Req'd: Y N

List Miscellaneous
Options Separately

Duo-Aire®

Duo-Aire reserves the right to make changes in design and specifications without prior notice.

Duo-Aire®

Duo-Aire®

SI-FP Front Face Make-up Air Canopy

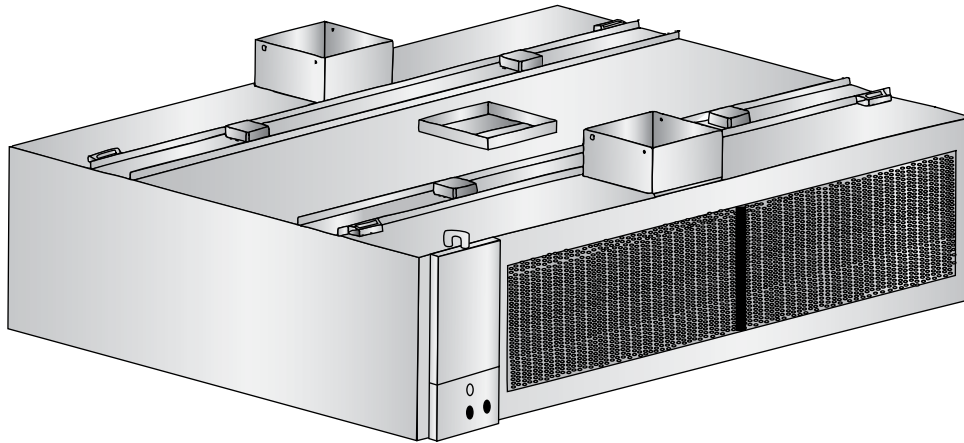

Model SI-FP

A single plenum front face discharge make-up air canopy constructed of stainless steel where visible and aluminized steel where concealed. All external seams shall be fluid welded and all internal seams shall be sealed with a high temperature silicone caulk. Supplied with fire damper and air volume damper. Perforated metal is used to diffuse the air and spread an even air flow across the face. Canopy shall be listed to meet NSF and UL standards and constructed to meet NFPA-96. Grease trough to be easily removable and slope to removable grease cup.

STANDARD FEATURES

- UL Listed Aluminum Grease Filters
- UL Listed Globe Lights
- Removable Grease Trough & Cup
- Front Face Double Deflection Aluminum Diffusers
- Exhaust & Supply Collars Installed
- Hanging Brackets
- UL Listed Fire and Air Volume Dampers in Supply Collar
- Flush Mounted Control Panel

OPTIONS

- All Stainless Steel Construction
- UL Listed Stainless Steel Grease Filters
- 14" Utility Cabinet for Fire Suppression System
- Electrical Control Panel
- Air Volume Controllers
- Pre-Plumbed Fire Suppression
- Stainless Steel Top Enclosures
- UL Listed Insulated Top and/or Ends for Zero Clearance to Combustible

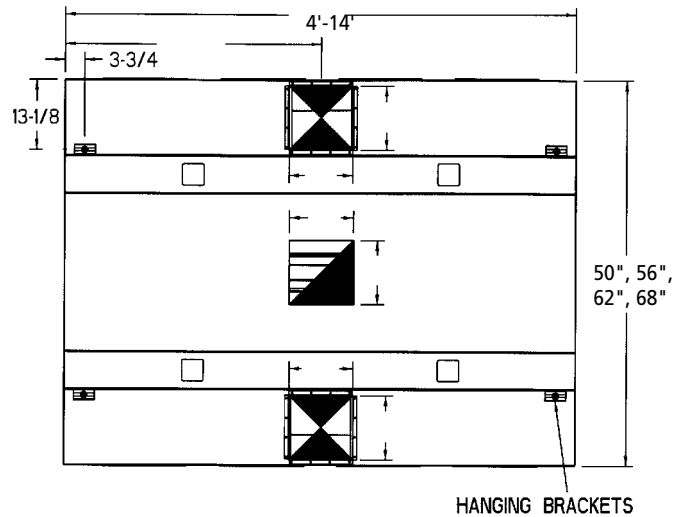

Plan View
(See reverse side for larger drawing)

BUILT IN
ACCORDANCE
WITH NFPA 96



SI-FP Series Specifications

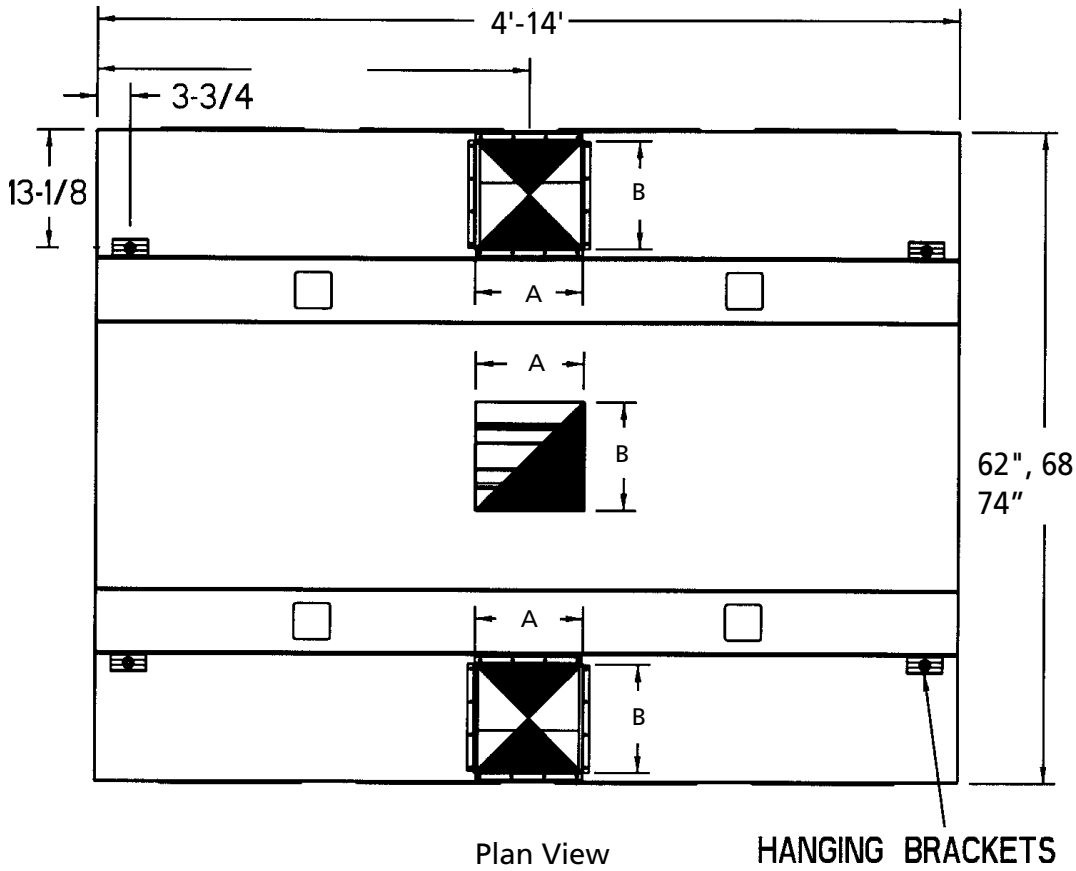

Plan View

HANGING BRACKETS

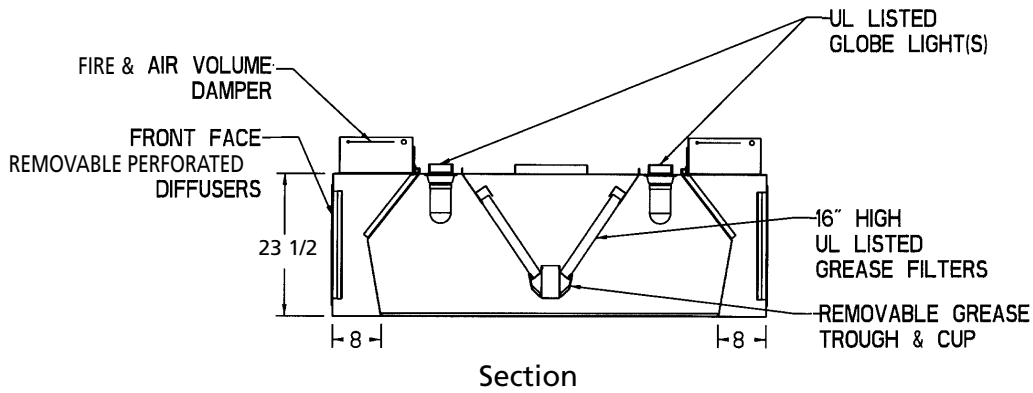

Section

EXHAUST AND SUPPLY RATE REQUIREMENTS

(Recommended Min. Exhaust Flow Rate)	TEMPERATURE OF EQUIPMENT		
	400°	600°	700°
CFM Exhaust / Ft.	400	500	650
CFM Supply / Ft.	320	400	520

ORDER ENTRY INFORMATION

Project:

Item:

Representative:

Model:

Length: Qty:

Width:
Height:

Duct - Concentric
Parallel

Exhaust CFM:
Supply CFM:

Entered by:

Date:

Drawings Req'd: Y N

List Miscellaneous
Options Separately

Duo-Aire®

Duo-Aire reserves the right to make changes in design and specifications without prior notice.

Duo-Aire®

Duo-Aire®

I-FP Front Face Make-up Air Canopy

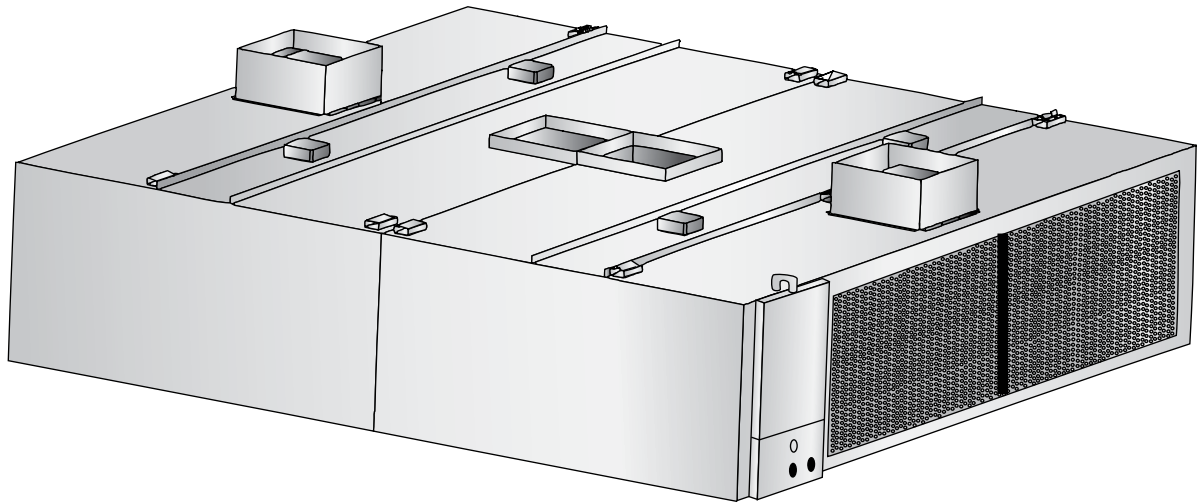

Model I-FP

A single plenum front face discharge make-up air canopy constructed of stainless steel where visible and aluminized steel where concealed. All external seams shall be fluid welded and all internal seams shall be sealed with a high temp. silicone caulk. Supplied with fire damper and air volume damper. Perforated metal is used to diffuse the air and spread an even air flow across the face. Canopy shall be listed to meet NSF and UL standards and constructed to meet NFPA-96. Grease trough to be easily removable and slope to removable grease cup.

STANDARD FEATURES

- UL Listed Aluminum Grease Filters
- UL Listed Globe Lights
- Removable Grease Trough & Cup
- Front Face Double Deflection Aluminum Diffusers
- Exhaust & Supply Collars Installed
- Hanging Brackets
- UL Listed Fire and Air Volume Dampers in Supply Collar
- Surface Mounted Control Panel

OPTIONS

- All Stainless Steel Construction
- UL Listed Stainless Steel Grease Filters
- 14" Utility Cabinet for Fire Suppression System
- Electrical Control Panel
- Pre-Plumbed Fire Suppression
- Stainless Steel Top Enclosures
- UL Listed Insulated Top and/or Ends for Zero Clearance to Combustible

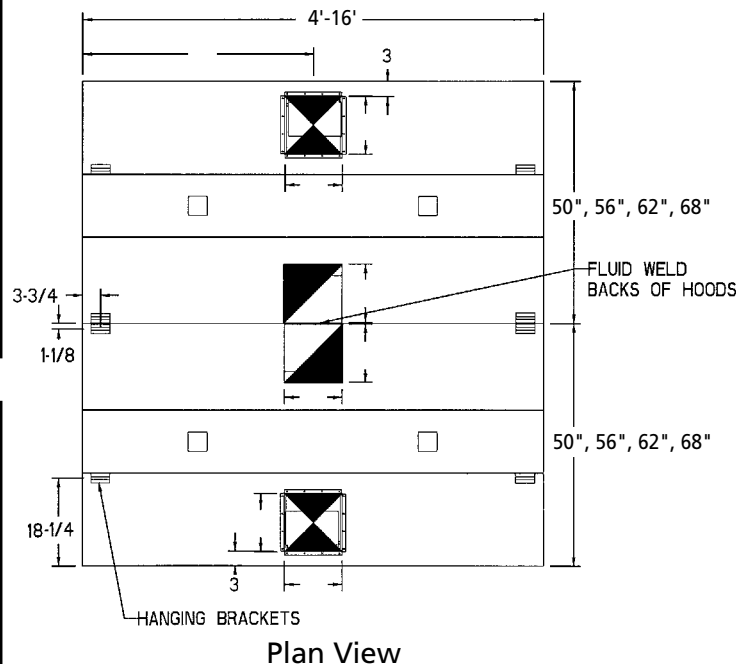

Note: Two exhaust ducts required after 12' long.

BUILT IN
ACCORDANCE
WITH NFPA 96



I-FP Island Style Series - Front Face Make-up Air Canopy

I-FP Series Specifications

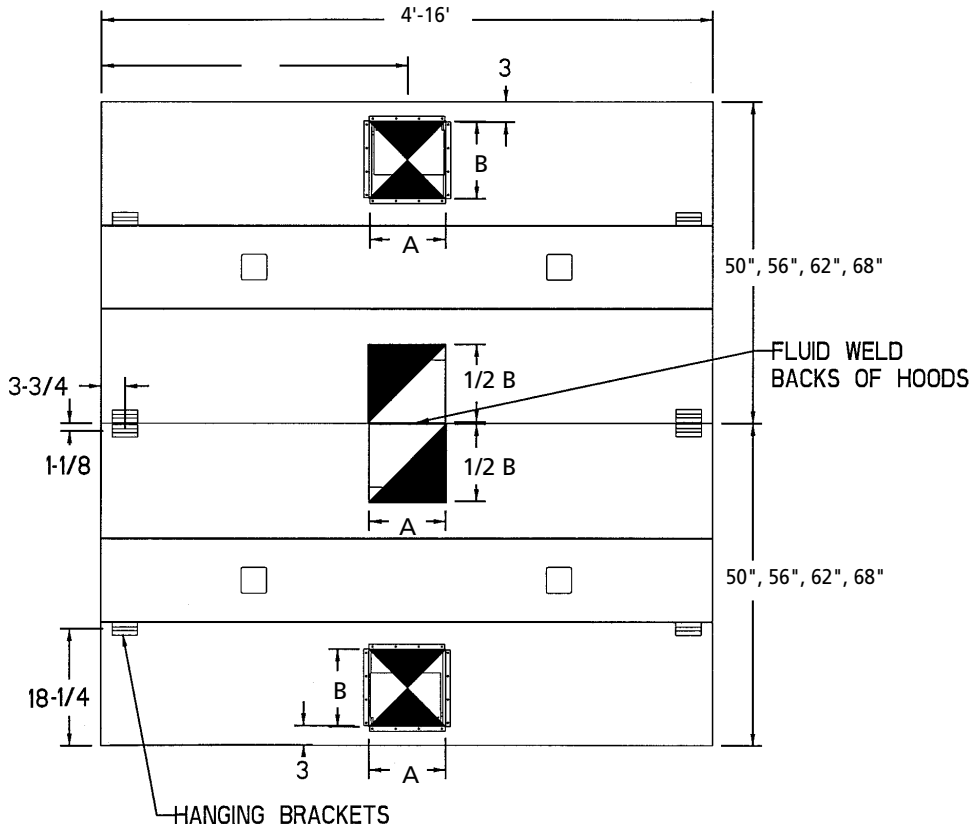

Plan View

Note: Two exhaust ducts required after 12' long.

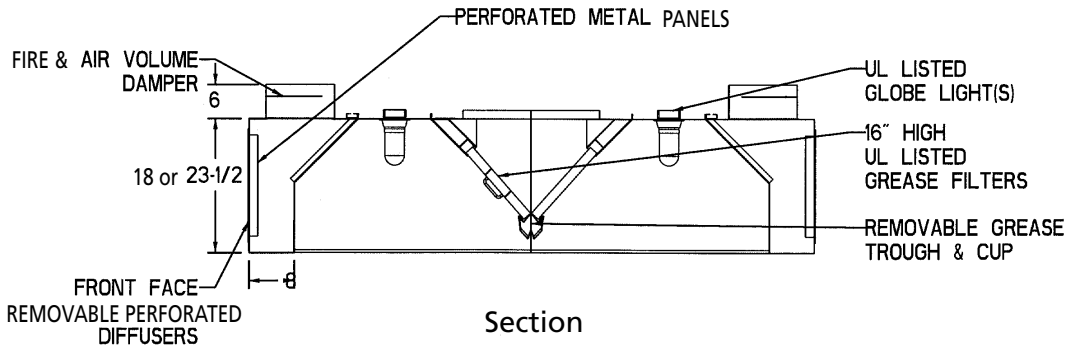

Section

EXHAUST AND SUPPLY RATE REQUIREMENTS

(Recommended Min. Exhaust Flow Rate)	TEMPERATURE OF EQUIPMENT		
	400°	600°	700°
CFM Exhaust / Ft.	550	600	700
CFM Supply / Ft.	440	480	560

ORDER ENTRY INFORMATION

Project:

Item:

Representative:

Model:

Length: Qty:

Width:
Height:

Duct - Concentric
Parallel

Exhaust CFM:
Supply CFM:

Entered by:

Date:

Drawings Req'd: Y N

List Miscellaneous
Options Separately

Duo-Aire®

Duo-Aire reserves the right to make changes in design and specifications without prior notice.

Duo-Aire®

Duo-Aire

I-FP-AVC Front Face Make-up Air Canopy

With Air Volume Controllers

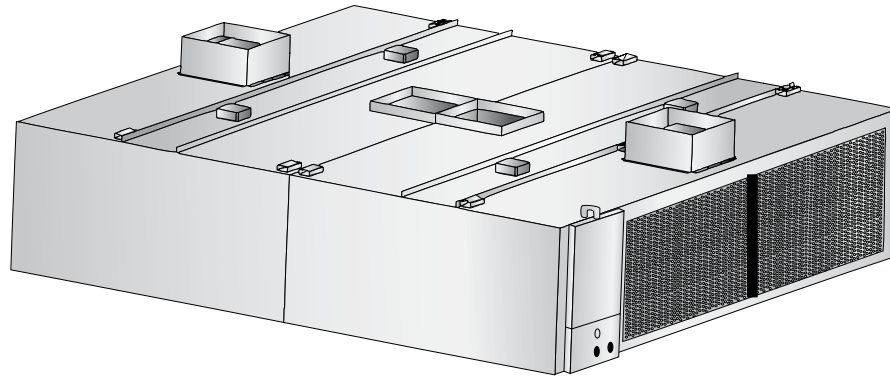

Model I-FP-AVC

A back to back single plenum front face discharge make-up air canopy constructed of stainless steel where visible and aluminized steel where concealed. All external seams shall be fluid welded and all internal seams shall be sealed with a high temp. silicone caulk. Supplied with fire damper and air volume damper. Perforated metal is used to diffuse the air and spread an even air flow across the face. Exhaust canopy to be equipped with stainless steel adjustable Air Volume Controllers installed directly behind the removable grease filters. Air Volume Controllers are to be factory installed and adjusted for the cooking equipment specified. Canopy shall be listed to meet NSF and UL standards and constructed to meet NFPA-96. Grease trough to be easily removable and slope to removable grease cup.

STANDARD FEATURES

- UL Listed Aluminum Grease Filters
- UL Listed Globe Lights
- Removable Grease Trough & Cup
- Exhaust & Supply Collars Installed
- Hanging Brackets
- Stainless Steel Adjustable Air Volume Controllers
- UL Listed Fire and Air Volume Dampers in Supply Collar
- Surface Mounted Control Panel

OPTIONS

- All Stainless Steel Construction
- UL Listed Stainless Steel Grease Filters
- 14" Utility Cabinet for Fire Suppression System
- Electrical Control Panel
- Pre-Plumbed Fire Suppression
- Stainless Steel Top Enclosures
- UL Listed Insulated Top and/or Ends for Zero Clearance to Combustible

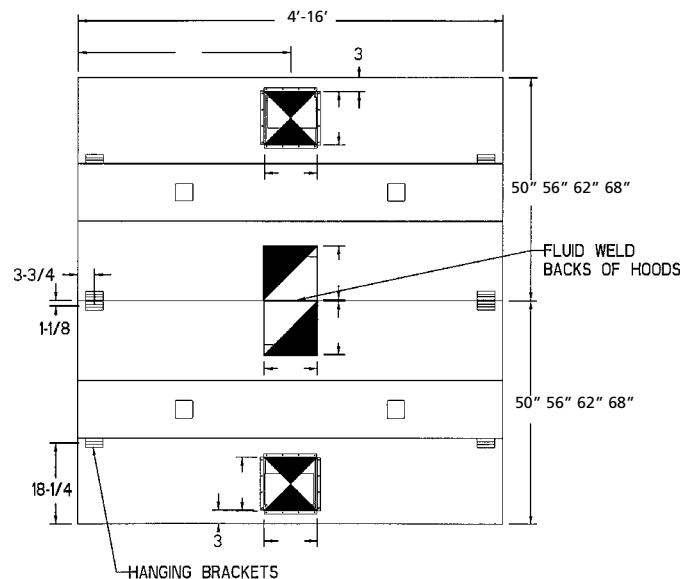

Plan View
(See reverse side for larger drawing)

BUILT IN
ACCORDANCE
WITH NFPA 96



I-FP-AVC Series - Front Face Make-up Air Canopy

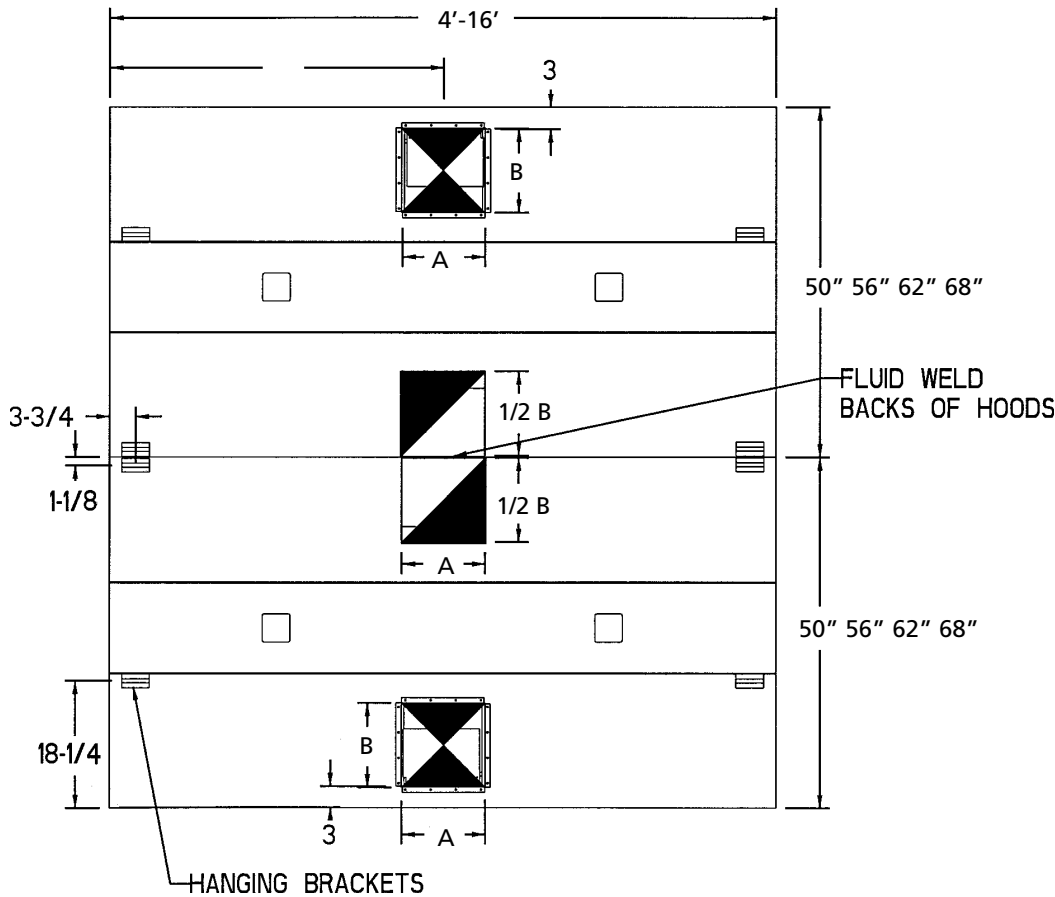

Plan View

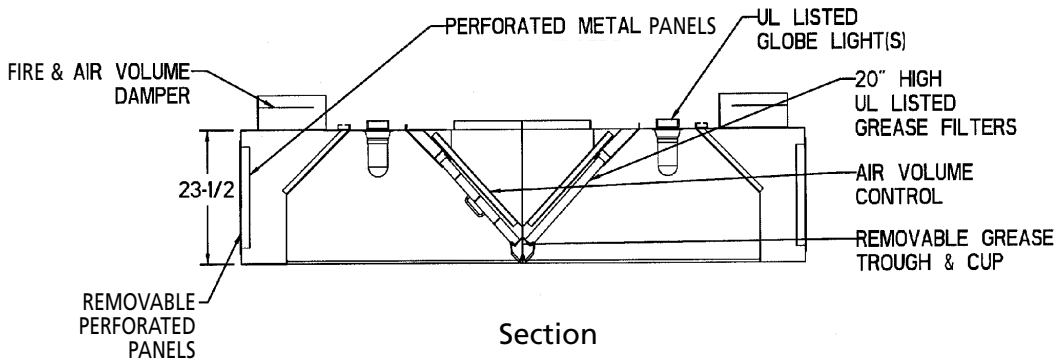

Section

EXHAUST AND SUPPLY RATE REQUIREMENTS

(Recommended Min. Exhaust Flow Rate)	TEMPERATURE OF EQUIPMENT		
	400°	600°	700°
CFM Exhaust / Ft.	400	500	-
CFM Supply / Ft.	320	400	-

ORDER ENTRY INFORMATION

Project:

Item:

Representative:

Model:

Length: Qty:

Width: Height:

Duct - Concentric
Parallel

Exhaust CFM:
Supply CFM:

Entered by:

Date:

Drawings Req'd: Y N

List Miscellaneous Options Separately



Duo-Aire reserves the right to make changes in design and specifications without prior notice.



ENGINEERING WORKSHEET

W-FP SERIES 400°F. EQUIPMENT

Length in Ft.	Exhaust CFM 275/Ft.	Exhaust Collar A X B	Duct Velocity FPM	Filter Area Sq. Ft.	Filter Velocity FPM	Exhaust Static Pressure	Supply CFM	Supply Velocity FPM	Supply Static Pressure	Supply Collar A X B
4	1100	10X10	1594	4.2	262	.75	880	313	.50	12x12
5	1375	12X10	1657	5.3	306	.75	1100	309	.50	12x12
6	1650	12X12	1650	6.3	262	.75	1320	306	.50	18x12
7	1925	14X12	1650	7.4	260	.75	1540	316	.50	18x12
8	2200	16X12	1650	8.4	262	.75	1760	313	.50	18x12
9	2475	18X12	1650	9.5	260	.75	1980	310	.50	24x12
10	2750	20X12	1650	10.5	262	.75	2200	309	.50	24x12
11	3025	22X12	1650	11.6	260	.75	2420	307	.50	24x12
12	3300	24X12	1650	12.6	262	.75	2640	306	.50	(2)18x12
13	3575	(2)13X12	1650	14.0	255	.75	2860	312	.50	(2)18x12
14	3850	(2)14X12	1650	15.0	257	.75	3080	310	.50	(2)18x12
15	4125	(2)15X12	1650	15.8	256	.75	3300	309	.50	(2)24x12
16	4400	(2)16X12	1650	16.8	262	.75	3520	308	.50	(2)24x12

W-FP SERIES 600°F. EQUIPMENT

Length in Ft.	Exhaust CFM 300/Ft.	Exhaust Collar A X B	Duct Velocity FPM	Filter Area Sq. Ft.	Filter Velocity FPM	Exhaust Static Pressure	Supply CFM	Supply Velocity FPM	Supply Static Pressure	Supply Collar A X B
4	1200	12X8	1791	4.2	286	1.0	960	342	.50	12x12
5	1500	12X10	1807	5.3	333	1.0	1200	337	.50	12x12
6	1800	12X12	1800	6.3	286	1.0	1440	334	.50	18x12
7	2100	14X12	1794	7.4	284	1.0	1680	345	.50	18x12
8	2400	16X12	1804	8.4	286	1.0	1920	341	.50	24x12
9	2700	18X12	1800	9.5	284	1.0	2160	338	.50	24x12
10	3000	20X12	1796	10.5	286	1.0	2400	337	.50	24x12
11	3300	22X12	1803	11.6	284	1.0	2640	335	.50	(2)18x12
12	3600	24X12	1800	12.6	286	1.0	2880	334	.50	(2)18x12
13	3900	(2)13X12	1800	14.0	279	1.0	3120	340	.50	(2)18x12
14	4200	(2)14X12	1800	15.0	280	1.0	3360	338	.50	(2)24x12
15	4500	(2)15X12	1800	15.8	280	1.0	3600	337	.50	(2)24x12
16	4800	(2)16X12	1804	16.8	286	1.0	3840	336	.50	(2)24x12

ENGINEERING WORKSHEET

W-FP-AVC SERIES 400°F. EQUIPMENT

Length in Ft.	Exhaust CFM 200Ft.	Exhaust Collar A X B	Duct Velocity FPM	Filter Area Sq. Ft.	Filter Velocity	Static Pressure FPM	Supply CFM	Supply Collar A X B	Supply Velocity FPM	Supply Static
4	800	8X8	1818	2.6	308	1.0	640	12x12	228	.50
5	1000	10X8	1786	3.4	294	1.0	800	12x12	225	.50
6	1200	12X8	1791	4.0	300	1.0	960	12x12	223	.50
7	1400	14X8	1795	4.6	304	1.0	1120	12x12	230	.50
8	1600	12X12	1600	5.4	296	1.0	1280	18x12	227	.50
9	1800	13X12	1662	6.0	300	1.0	1440	18x12	226	.50
10	2000	14X12	1714	6.8	294	1.0	1600	18x12	225	.50
11	2200	15X12	1760	7.4	297	1.0	1760	24x12	224	.50
12	2400	16X12	1804	8.0	300	1.0	1920	24x12	222	.50
13	2600	18X12	1733	8.9	292	1.25	2080	24x12	227	.50
14	2800	19X12	1768	9.6	292	1.25	2240	24x12	226	.50
15	3000	20X12	1796	10.0	300	1.25	2400	24x12	225	.50
16	3200	22X12	1745	10.8	296	1.25	2560	24x12	224	.50

W-FP-AVC SERIES 600°F. EQUIPMENT

Length in Ft.	Exhaust CFM 250Ft.	Exhaust Collar A X B	Duct Velocity FPM	Filter Area Sq. Ft.	Filter Velocity	Static Pressure FPM	Supply CFM	Supply Collar A X B	Supply Velocity FPM	Supply Static
4	1000	10X8	1786	2.6	385	1.25	800	12x12	228	.50
5	1250	12X8	1866	3.4	368	1.25	1000	12x12	281	.50
6	1500	12X10	1807	4.0	375	1.25	1200	18x12	278	.50
7	1750	12X12	1750	4.6	380	1.25	1400	18x12	287	.50
8	2000	14X12	1714	5.4	370	1.25	1600	18x12	284	.50
9	2250	16X12	1688	6.0	375	1.25	1800	18x12	282	.50
10	2500	18X12	1667	6.8	368	1.25	2000	24x12	281	.50
11	2750	19X12	1737	7.4	372	1.25	2200	24x12	280	.50
12	3000	20X12	1796	8.0	375	1.25	2400	24x12	278	.50
13	3250	22X12	1773	8.9	365	1.50	2600	(2)18x12	283	.50
14	3500	24X12	1750	9.6	365	1.50	2800	(2) 18x12	282	.50
15	3750	26X12	1731	10.0	375	1.50	3000	(2) 18X12	281	.50
16	4000	28X12	1714	10.8	370	1.50	3200	(2) 18X12	280	.50

ENGINEERING WORKSHEET

SI-FP SERIES 400°F. EQUIPMENT

Length in Ft.	Exhaust CFM 400/Ft.	Exhaust Collar A X B	Duct Velocity FPM	Filter Area Sq. Ft.	Filter Velocity FPM	Exhaust Static Pressure	Supply CFM	Supply Velocity FPM	Supply Static Pressure	Supply Collar A X B
4	1600	12X12	1600	8.4	190	.75	1280	300	.50	(2)12x12
5	2000	14X12	1709	10.6	189	.75	1600	300	.50	(2)12x12
6	2400	16X12	1804	12.6	191	.75	1920	300	.50	(2)12x12
7	2800	19X12	1768	14.8	189	.75	2240	300	.50	(2)18x12
8	3200	22X12	1745	16.8	191	.75	2560	300	.50	(2)18x12
9	3600	24X12	1800	19.0	190	.75	2880	300	.50	(2)18x12
10	4000	24X14	1717	21.0	191	.75	3200	300	.50	(2)18x12
11	4400	26X14	1746	23.2	190	.75	3520	300	.50	(4)12x12
12	4800	28X14	1765	25.2	191	.75	3840	300	.50	(4)12x12
13	5200	30X14	1783	28.0	186	.75	4160	300	.50	(4)18x12
14	5600	32X14	1800	30.0	187	.75	4480	300	.50	(4)18x12

SI-FP SERIES 600°F. EQUIPMENT

Length in Ft.	Exhaust CFM 500/Ft.	Exhaust Collar A X B	Duct Velocity FPM	Filter Area Sq. Ft.	Filter Velocity FPM	Exhaust Static Pressure	Supply CFM	Supply Velocity FPM	Supply Static Pressure	Supply Collar A X B
4	2000	14X12	1709	8.4	238	1.0	1600	360	.50	(2)12x12
5	2500	17X12	1765	10.6	236	1.0	2000	360	.50	(2)12x12
6	3000	20X12	1800	12.6	238	1.0	2400	360	.50	(2)12x12
7	3500	24X12	1750	14.8	237	1.0	2800	360	.50	(2)18x12
8	4000	24X14	1714	16.8	238	1.0	3200	360	.50	(2)24x12
9	4500	26X14	1779	19.0	237	1.0	3600	360	.50	(2)24x12
10	5000	28X14	1838	21.0	238	1.0	4000	360	.50	(2)24x12
11	5500	28X16	1768	23.2	237	1.0	4400	360	.50	(4)18x12
12	6000	28X18	1714	25.2	238	1.0	4800	360	.50	(4)18x12
13	6500	28X20	1675	28.0	232	1.0	5200	360	.50	(4)18x12
14	7000	28X22	1635	30.0	233	1.0	5600	360	.50	(4)18x12

ENGINEERING WORKSHEET

I-FP SERIES

400°F. EQUIPMENT

Length in Ft.	Exhaust CFM 550/Ft.	Exhaust Collar A X B	Duct Velocity FPM	Filter Area Sq. Ft.	Filter Velocity FPM	Exhaust Static Pressure	Supply CFM	Supply Velocity FPM	Supply Static Pressure	Supply Collar A X B
4	2200	14 x 13	1740	8.4	175	.75	1760	313	.50	(2)12x12
5	2750	16 x 15	1650	10.6	174	.75	2200	309	.50	(2)12x12
6	3300	17 x 17	1644	12.6	168	.75	2640	306	.50	(2)12x12
7	3850	18 x 18	1711	14.8	175	.75	3080	316	.50	(2)18x12
8	4400	20 x 19	1667	16.8	173	.75	3520	313	.50	(2)18x12
9	4950	21 x 20	1697	19.0	174	.75	3960	310	.50	(2)24x12
10	5500	24 x 20	1650	21.0	174	.75	4400	309	.50	(2)24x12
11	6050	26 x 20	1675	23.2	174	.75	4840	307	.50	(2)24x12
12	6600	28 x 20	1697	25.2	174	.75	5280	306	.50	(4)18x12
13	7150	(2)18 x 17	1682	28.0	169	.75	5720	312	.50	(4)18x12
14	7700	(2)18 x 18	1711	30.0	169	.75	6160	310	.50	(4)18x12
15	8250	(2)19 x 19	1645	31.6	170	.75	6600	309	.50	(4)24x12
16	8800	(2)20 x 19	1667	32.4	158	.75	7040	308	.50	(4)24x12

I-FP SERIES

600°F. EQUIPMENT

Length in Ft.	Exhaust CFM 600/Ft.	Exhaust Collar A X B	Duct Velocity FPM	Filter Area Sq. Ft.	Filter Velocity FPM	Exhaust Static Pressure	Supply CFM	Supply Velocity FPM	Supply Static Pressure	Supply Collar A X B
4	2400	16X12	1791	8.4	190	1.0	1920	342	.50	(2)12x12
5	3000	20X12	1807	10.6	190	1.0	2400	337	.50	(2)12x12
6	3600	24X12	1800	12.6	184	1.0	2880	334	.50	(2)18x12
7	4200	24X14	1794	14.8	191	1.0	3360	345	.50	(2)18x12
8	4800	24X16	1804	16.8	189	1.0	3840	341	.50	(2)24x12
9	5400	24X18	1800	19.0	190	1.0	4320	338	.50	(2)24x12
10	6000	24X20	1796	21.0	190	1.0	4800	337	.50	(2)24x12
11	6600	24X22	1803	23.2	190	1.0	5280	335	.50	(4)18x12
12	7200	24X24	1800	25.2	190	1.0	5760	334	.50	(4)18x12
13	7800	(2)18X18	1733	28.0	184	1.0	6240	340	.50	(4)18x12
14	8400	(2)19X18	1768	30.0	186	1.0	6720	338	.50	(4)24x12
15	9000	(2)20X19	1705	31.6	186	1.0	7200	337	.50	(4)24x12
16	9600	(2)20X20	1728	32.4	190	1.0	7680	336	.50	(4)24x12

ENGINEERING WORKSHEET

I-FP-AVC SERIES 400°F. EQUIPMENT

Length in Ft.	Exhaust CFM 400Ft.	Exhaust Collar A X B	Duct Velocity FPM	Filter Area Sq. Ft.	Filter Velocity FPM	Static Pressure	Supply CFM	Supply Collar A X B	Supply Velocity FPM	Supply Static
4	1600	12 x 12	1600	5.2	308	1.0	1280	(2)12X12	228	.50
5	2000	14 x 12	1714	6.8	294	1.0	1600	(2)12X12	225	.50
6	2400	14 x 14	1763	8.0	300	1.0	1920	(2)12X12	223	.50
7	2800	16 x 15	1680	9.2	304	1.0	2240	(2)12X12	230	.50
8	3200	17 x 16	1694	10.8	296	1.0	2560	(2)18X12	227	.50
9	3600	18 x 17	1694	12.0	300	1.0	2880	(2)18X12	226	.50
10	4000	19 x 18	1684	13.6	294	1.0	3200	(2)18X12	225	.50
11	4400	20 x 19	1667	14.8	297	1.0	3520	(2)18X12	224	.50
12	4800	20 x 20	1728	16.0	300	1.0	3840	(2)24X12	222	.50
13	5200	22 x 20	1702	17.8	292	1.25	4160	(2)24X12	227	.50
14	5600	24 x 20	1680	19.2	292	1.25	4480	(2)24X12	226	.50
15	6000	26 x 20	1662	20.0	300	1.25	4800	(2)24X12	225	.50
16	6400	28 x 20	1645	21.6	296	1.25	5120	(2)24X12	224	.50

I-FP-AVC SERIES 600°F. EQUIPMENT

Length in Ft.	Exhaust CFM 500Ft.	Exhaust Collar A X B	Duct Velocity FPM	Filter Area Sq. Ft.	Filter Velocity FPM	Static Pressure	Supply CFM	Supply Collar A X B	Supply Velocity FPM	Supply Static
4	2000	14 x 12	1714	5.2	385	1.25	1600	(2)12X12	228	.50
5	2500	15 x 14	1714	6.8	368	1.25	2000	(2)12X12	281	.50
6	3000	16 x 16	1688	8.0	375	1.25	2400	(2)12X12	278	.50
7	3500	18 x 17	1647	9.2	380	1.25	2800	(2)18X12	287	.50
8	4000	19 x 18	1684	10.8	370	1.25	3200	(2)18X12	284	.50
9	4500	20 x 20	1620	12.0	375	1.25	3600	(2)18X12	282	.50
10	5000	22 x 20	1636	13.6	368	1.25	4000	(2)24X12	281	.50
11	5500	24 x 20	1650	14.8	372	1.25	4400	(2)24X12	280	.50
12	6000	26 x 20	1661	16.0	375	1.25	4800	(4)18X12	278	.50
13	6500	28 x 20	1671	17.8	365	1.50	5200	(4)18X12	283	.50
14	7000	28 x 22	1636	19.2	365	1.50	5600	(4)24X12	282	.50
15	7500	28 x 24	1607	20.0	375	1.50	6000	(4)24X12	281	.50
16	8000	30 x 24	1600	21.6	370	1.50	6400	(4)24X12	280	.50