

# Duo-Aire

INC.

## INSTALLATION MANUAL

This manual provides installation & operating instructions



BUILT IN  
ACCORDANCE  
WITH  
NFPA 96



### **NOTIFY CARRIER OF DAMAGE AT ONCE.**

It is the responsibility of the consignee to inspect the container upon receipt of same and to determine the possibility of any damage, including concealed damage. Duo-Aire suggests that if you are suspicious of damage to make a notation on the delivery receipt. It will be the responsibility of the consignee to file a claim with the carrier. We recommend that you do so at once.

Retain this manual for future reference.

Notice: Due to a continuous program of product improvement, Duo-Aire reserves the right to make changes in design and specifications without prior notice.

Notice: Please read the entire manual carefully before installation. If certain recommended procedures are not followed, warranty claims will be denied.

Model Number \_\_\_\_\_

Serial Number \_\_\_\_\_

Installation Date \_\_\_\_\_

### **Safety Procedures**

- Always Disconnect power cord before attempting to work on or to clean equipment. Turning the switch off is insufficient as the power remains live to the cabinet and can be a hazard.
- Route the power cord so that it is not likely to be walked on or pinched by other appliances.
- Do not overload outlets with too many appliances. This can result in fire or electrical shock.
- Disconnect plug when the appliance will be idled for a long period of time.
- Do not attempt to service this unit yourself as removing covers may cause unnecessary exposure to dangerous voltage.
- Never connect the unit to a power source while standing in water. Wet hands and wet floors should be avoided when connecting any electrical appliance to a power outlet.
- When a replacement part is required, always insist on factory authorized parts.

# Index

## INSTALLATION INSTRUCTIONS

Installation Requirements for Duo-Aire Hoods .....	Page 2
Canopy Hoods .....	Page 2
Low Side Wall Ventilators .....	Page 3
Pizza Oven Hoods .....	Page 4
Exhaust Fans & Ducts .....	Page 5
Fresh Air Supply Fans .....	Page 6
Hoods with Air Volume Controllers - Adjustment Instructions .....	Page 7
Side Skirts .....	Page 8
Top Enclosure Panels .....	Page 9
Stainless Steel Wall Panels .....	Page 10

## OPERATING INSTRUCTIONS    START - CHECK - BALANCE

Direct Draw Hoods .....	Page 11
Make-Up Air Hoods .....	Page 12

## FINAL AIR BALANCE

Make-Up Air Hoods .....	Page 12
Air Balance Report .....	Page 13
Notes and Worksheet .....	Page 14

# INSTALLATION INSTRUCTIONS

## Installation Requirements For All Duo-Aire Hoods

Duo-Aire hoods are provided with slotted hanging brackets designed to receive 1/2" threaded rod with a 1/2" bolt and washer. Supporting rods must be connected to all factory installed brackets. Recommended hanging height is 6'- 6" above finished floor for canopies. Low side wall ventilators should be installed directly upon a Duo-Aire base or on a fire rated wall. If wall mounted, the bottom of the vent should be 36" above finished floor.

ALL DUO-AIRE VENTILATION SYSTEMS MUST BE INSTALLED IN ACCORDANCE WITH NFPA-96, REMOVAL OF SMOKE AND GREASE-LADEN VAPORS FROM COMMERCIAL COOKING EQUIPMENT.

## CANOPIES

1. Check all local codes prior to installation. Special requirements may be necessary depending upon building material construction.
2. Move crated hood to location of installation and very carefully uncrate hood.
3. Raise hood to proper hanging height.
4. Suspend hood from adequate roof supports using 1/2" threaded rods with nuts and washers. (See Fig. 1)
5. Level hood left to right and front to back.
6. Brackets are provided for hoods which are to be installed end to end or back to back. Bolt brackets together using 3/8" bolt through holes provided. (See Fig. 2)
7. Install "C" channel where the ends of hood meet and install "T" moldings on front face of hoods where they join. High temperature silicone can be used to install "C" and "T" moldings. (See Fig. 3)
8. For Make-up air hoods, the supply collar with built-in U.L. listed fire damper, and air volume damper must be installed per instructions on collar.
9. Provide a removable service door in supply duct near fire damper. (See Fig. 5)

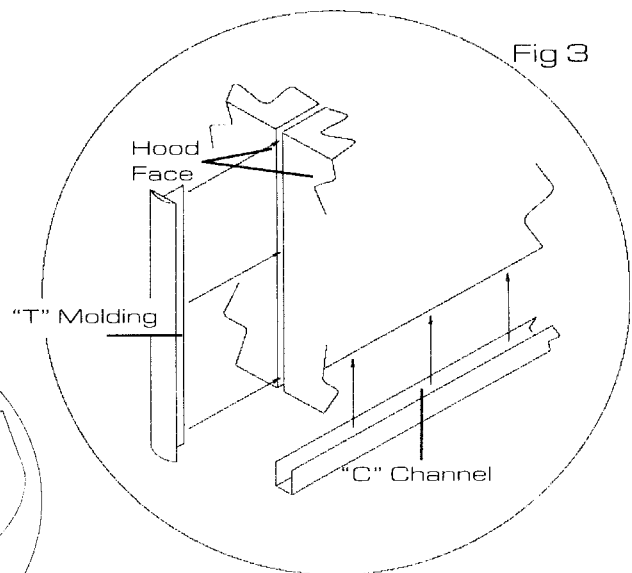
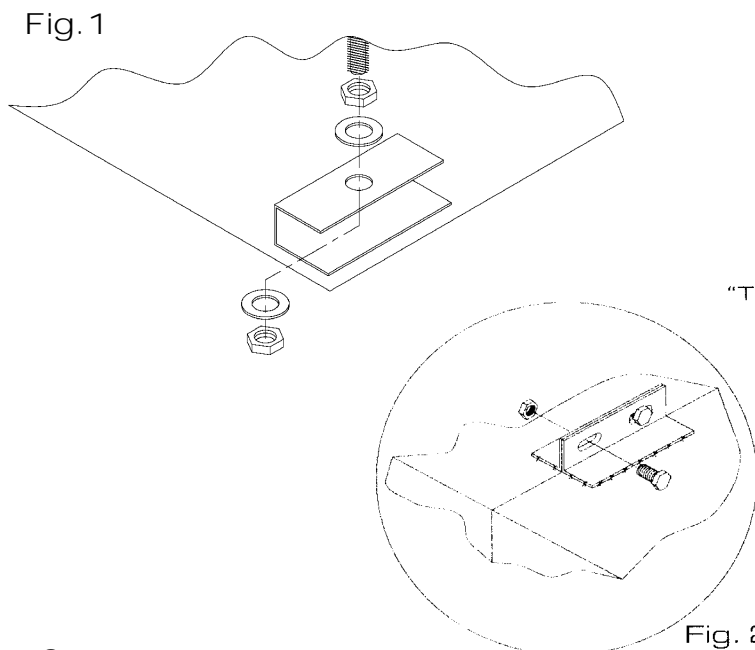

## LOW SIDE WALL VENTILATORS

1. Check all local codes prior to installation. Special requirements may be necessary depending upon building material construction.
2. Move crated hood to location of installation and very carefully uncrate vent.
3. If vent is base mounted, base must be installed and leveled front to back and left to right.
4. Place vent on base. Secure vent to base by screwing side walls of vent to base. (See Fig. 4)
5. If vent is wall mounted, place vent on wall, level front to back and left to right, then bolt metal hanging bracket located on top of hood to wall. (See Fig. 4)
6. Bottom of ventilator should be 36" above finished floor. (See Fig. 5)
7. Fluid weld exhaust duct to hood exhaust duct collar. (See Fig. 5)
8. For Make-up air ventilators, the supply collar with built-in U.L. listed fire damper, and air volume damper must be installed per instructions on collar.
9. Attach air supply duct work to supply collar. **DO NOT SCREW INTO FIRE DAMPER.**
10. Provide a removable service door in supply duct near fire damper. (See Fig. 5)

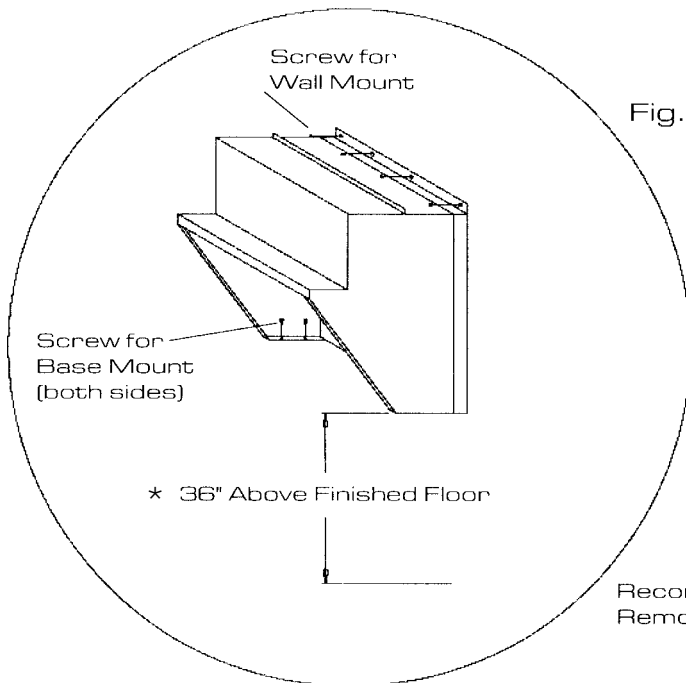

[Typical of all make-up air vents]  
Fig. 5

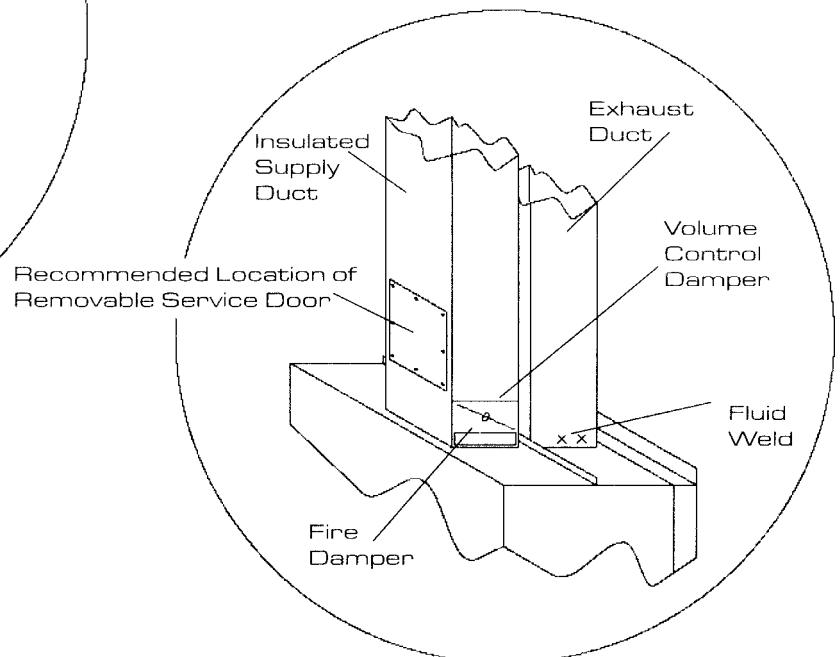

\* WHEN USING FLOOR FRYERS,  
CONFIRM FLUE HEIGHT

## PIZZA OVEN HOODS

### Deck Oven Installation: (Model VPO)

1. Check all local codes prior to installation. Special requirements may be necessary depending upon building material construction.
2. Move crated hood to location of installation and very carefully uncrate vent.
3. Place hood directly on top of pizza oven.
4. Install exhaust duct from hood exhaust collar to exhaust fan and curb.

### Conveyor Pizza Oven Installation: (Model VCP)

1. Check all local codes prior to installation. Special requirements may be necessary depending upon building material construction.
2. Move crated hood to location of installation and very carefully uncrate vent.
3. Suspend hood from adequate roof supports using 1/2" threaded rods & nuts and washers. (See Fig. 1 Page 2)
4. Hood should be hung 1/2" above top of oven.
5. Install exhaust duct from hood exhaust collar to exhaust fan and curb.

### Conveyor Pizza Oven Installation: (Model VEC)

1. Check all local codes prior to installation. Special requirements may be necessary depending upon building material construction.
2. Move crated hood to location of installation and very carefully uncrate vent.
3. Place hood directly on top of pizza oven. Hood will rest on 1 1/2" clips located on inside of both hood sections
4. Install hood with duct cleanout cover plate facing toward room not toward wall.
5. Install exhaust duct from hood exhaust collar to exhaust fan and curb.

## EXHAUST FAN & DUCT

1. Check all local codes prior to installation.
2. All exhaust fans are supplied with a minimum 18" high metal curb, hinge kit, and grease box.
3. The exhaust fan curb should be installed directly above the hood if possible. Always maintain the shortest duct run possible.
4. Cut hole and seal exhaust fan curb to roof.
5. Place exhaust fan on curb
6. Install hinges on exhaust fan cap and metal curb. Remember to leave ample room for fan to tilt back. Fan will remain in tilted back position.
7. Install grease collection box on side of fan that has grease tube discharge.
8. The exhaust duct must be constructed of 16 GA. carbon steel or 18 GA. stainless steel. All seams must be fluid welded.
9. A duct transition should be provided below exhaust fan inlet.
10. The exhaust duct must be fluid welded to hood collar.
11. Make all necessary electrical connections and check fan for proper rotation.  
**"NOTE": Fan will exhaust air running in wrong direction.**

Fig. 6

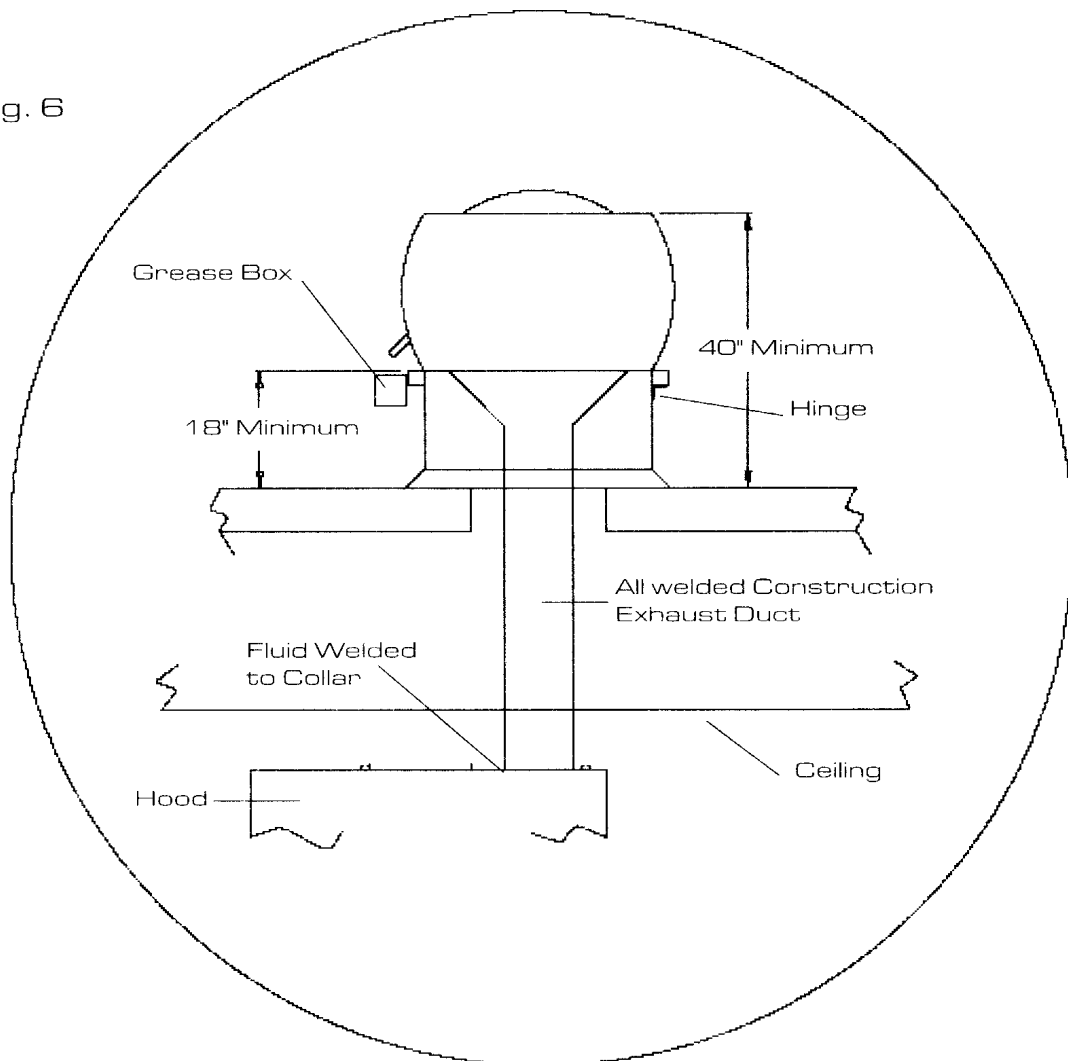

## FRESH AIR SUPPLY FAN

1. Check all local codes prior to installation.
2. Supply fan inlet must be located a minimum 10'-0" from the exhaust fan. If 10'-0" is not possible a 3' vertical separation may be acceptable\* .
3. Cut and seal supply fan curb to roof.
4. Duct shall be constructed of 22 or 24 gauge steel. Insulated duct material should be used to eliminate frost and/or condensation.
5. Duct shall be sized to provide air velocities not exceeding 1200 FPM.
6. A volume control damper, provided in the duct just above the supply collar that contains the U.L. listed fire damper, should be properly set to supply CFM required.
7. If the hood is provided without the supply collar installed, it must be installed per the instructions provided on the collar.
8. Carefully place the supply fan on roof curb. Face supply fan inlet away from prevailing winter wind. Electrical back draft damper is recommended in cold climates.
9. Bolt or screw fan to fan curb.
10. Make all necessary electrical connections and check fan for proper rotation.  
**"NOTE": Fan will supply air running in wrong direction.**

\* Dependent on local code requirements.

Fig. 7

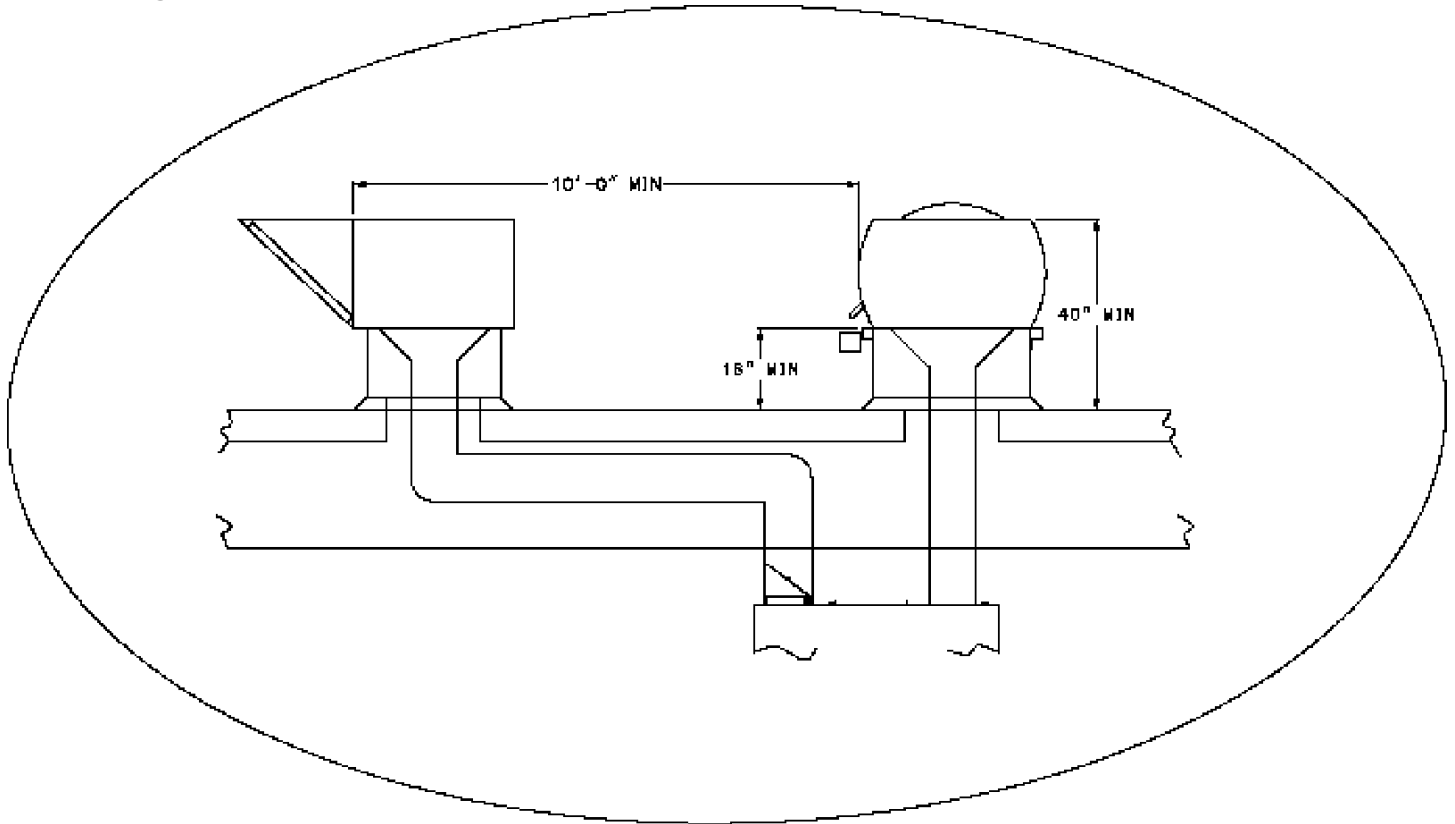



## HOOD WITH AIR VOLUME CONTROLLERS

Some Duo-Aire canopy hoods will be designed with our patented Air Volume Controllers (AVC) located directly behind the standard filter bank. The AVC are specially designed to exhaust high volumes of air over high heat - high grease producing equipment and low volumes of air over low heat - low grease producing equipment thereby reducing the total exhaust volume.

The AVC were factory set, based on the cooking equipment specified on the approved drawings, therefore the AVC will not have to be adjusted. If, however, the cooking equipment has changed or should change in the future, the following procedure should be followed.

### AVC ADJUSTMENT INSTRUCTIONS

1. Remove all grease filters from the hood.
2. Loosen retaining screws on channels holding the AVC at each end.
3. Slide AVC up or down as needed. The higher the AVC is moved the greater will be the exhaust volume.
4. Reset the retaining screw at the desired position.
5. Replace grease filters.

Fig.8

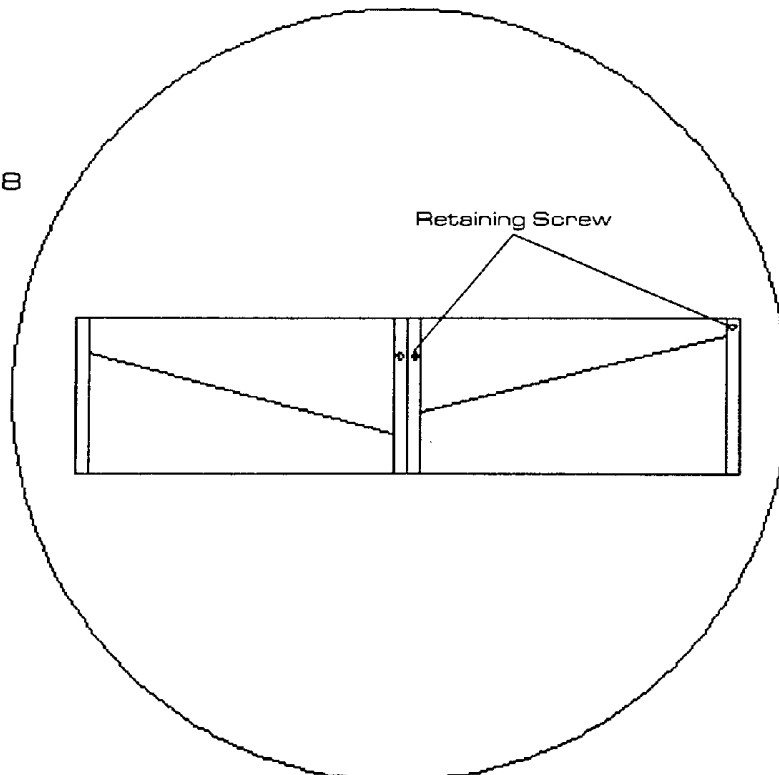

## INSTALLATION OF SIDE SKIRTS

### Pieces Provided

One or two optional side skirts may be provided.

### INSTALLATION

1. Side skirts are off set at the top and have a 90° bend inward at the rear.
2. Skirts are to overlap the outside of the hood. Bolts and acorn nuts should be attached per the drawing. (Stainless bolts & acorn nuts supplied).
3. Skirt flange should be screwed to the wall (screws not provided).

Fig.9

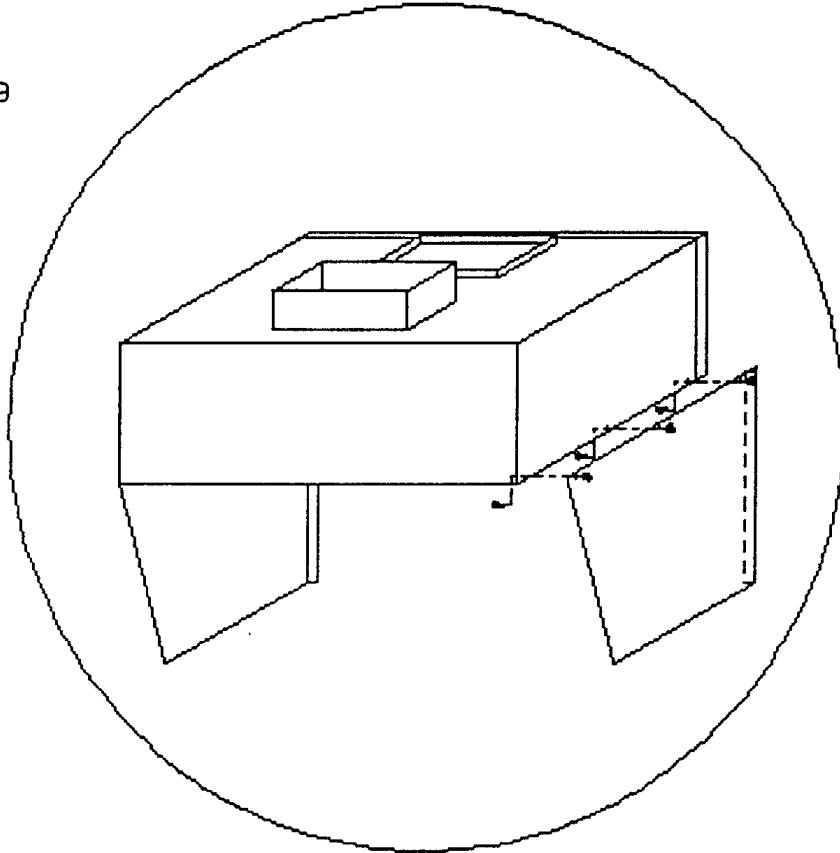

# TOP ENCLOSURES

## INSTALLATION OF ENCLOSURE PANELS

### Pieces Provided

Enclosure panels are provided for exposed ends and front of hood(s).

### INSTALLATION INSTRUCTIONS

1. Hoods ordered with enclosure panels will be shipped with threaded metal studs installed on perimeter of hood top where panels are to be installed. Retaining nuts and washers are installed on the studs prior to shipping.
2. Loosen nuts on studs. Slide enclosure panel under loosened nuts. Holes in panels are open on end so nuts do not have to be removed.
3. If enclosure panels are installed on one or more hoods butted end to end, the butting ends of the front enclosure panels should be bolted together.

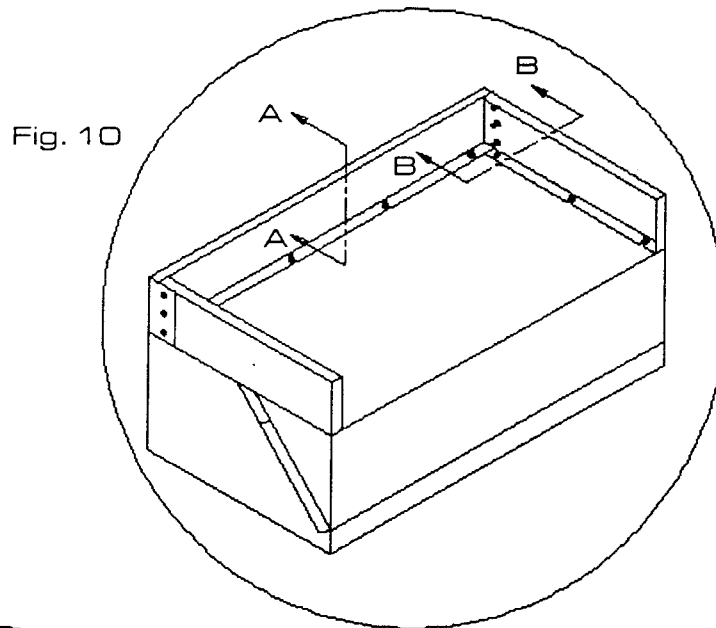
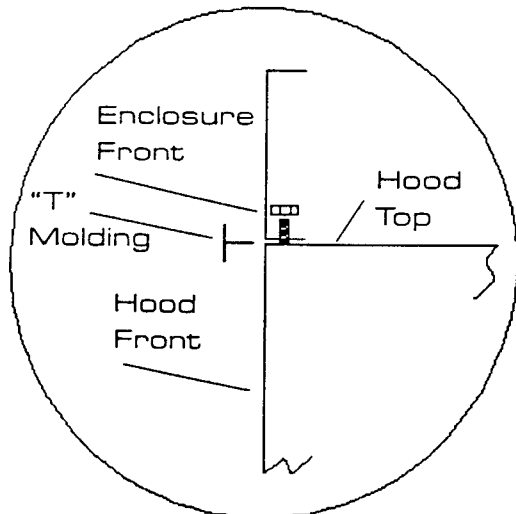
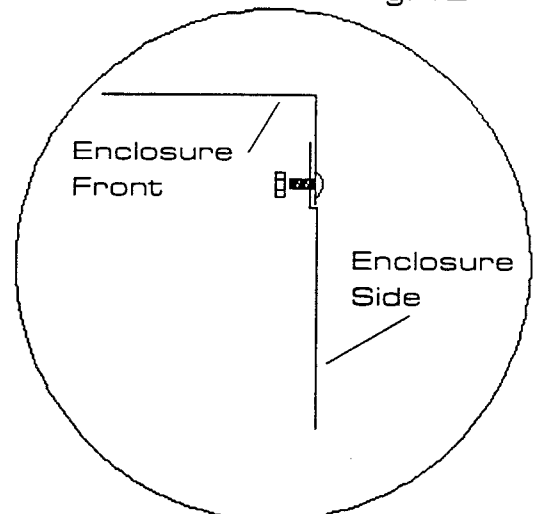

Fig. 11



Section A A

Fig. 12



Section B B

## INSTALLATION OF INSULATED STAINLESS STEEL WALL PANELS

### Pieces Provided

Insulated wall panel comes in two pieces. Each piece will be the same length as the hood.

- A. Top panel will have a 1" flange full length top and bottom and, interlocking slots located on the bottom.
- B. Bottom panel will have interlocking tabs on top and full length 1" flange on bottom.

### INSTALLATION INSTRUCTIONS FOR INSULATED WALL PANEL ( See Fig. 13)

1. Install wall panels prior to hanging hood(s).
2. Install top panel first. Top of panel should be installed 6'-6" A.F.F. and level. Screw panel to wall making sure slotted holes are facing floor.
3. Install lower panel by sliding tabs into slotted holes in upper panel, screw bottom flange to wall.
4. Caulk horizontal seam with NSF approved silicone sealant.
5. When hood is hung it will rest on top panel.

**NOTE: be careful not to damage wall panel face when installing hood.**

Fig. 13

Insulated Wall Panel

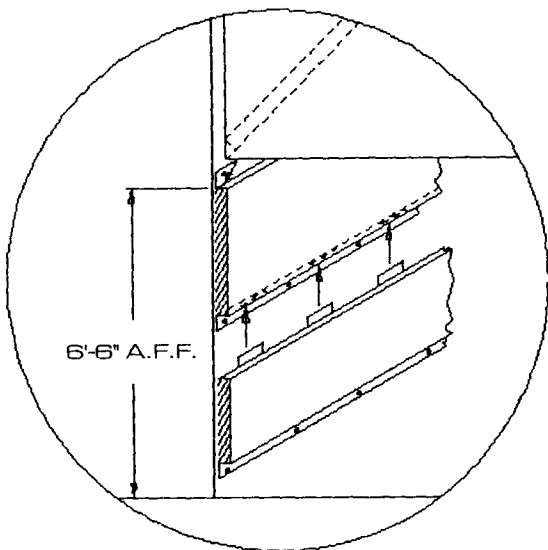
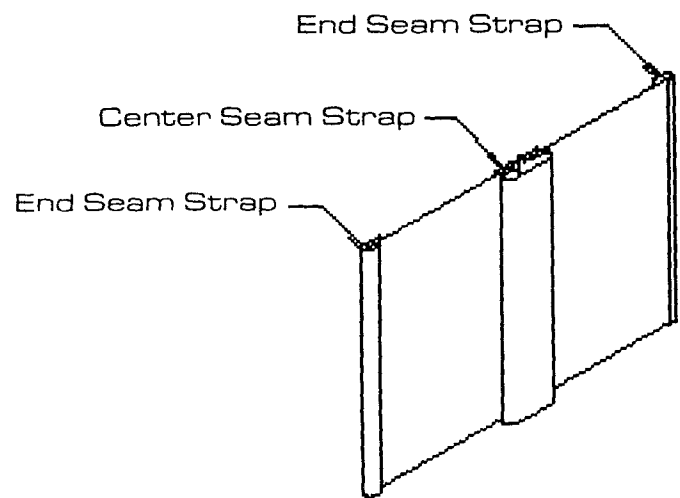

Fig. 14

Single thickness Wall Panel



### INSTALLATION INSTRUCTIONS FOR SINGLE THICKNESS WALL PANEL ( See Fig. 14)

1. Install wall panels prior to hanging hood(s).
2. Install seam strips at proper locations and screw to wall.
3. Apply glue to wall between seam strips.
4. Slip one end of wall panel into seam strip, pull out middle of panel and slip other end of panel into other seam strip. Gently apply pressure over entire wall panel to secure to wall.

## START - CHECK - BALANCE

### DIRECT DRAW HOODS

1. Close all doors and windows.
2. Operate all exhaust fans, Make-up air unit and building HVAC.
3. Turn on all cooking equipment under the hood to preheat to operating temperature.
4. Produce large quantities of smoke.
5. Observe capture of vapors.
6. If all vapors are not captured, increase exhaust fan RPM.
7. Check air pressure in kitchen. Pressure must be negative relative to dining room pressure.
8. Air velocities entering the kitchen from the dining room should not exceed 100 FPM. No air should be moving toward the dining area.
9. Repeat steps 6 and 7 until all vapors are captured.

#### NOTE:

The exhaust and supply (if any) air flow rates were established under controlled laboratory conditions, and greater exhaust and/or lesser supply air may be required for complete vapor and smoke removal in specific installations

## START - CHECK - BALANCE

### MAKE-UP AIR HOODS

#### EXHAUST FAN(S)

1. Open all doors and/or windows leading to outside.
2. Start the exhaust fan only. Do not run the supply fan or Make-up air unit.
3. Refer to Duo-Aire drawings and/or U.L. information label on hood for proper FPM and CFM requirements.
4. Adjust speed of exhaust fan to obtain proper air velocities and CFM through grease filters.

#### SUPPLY FAN OR MAKE-UP AIR UNIT

1. Start the supply fan and/or Make-up air unit only. Do not run the exhaust fan.
2. Refer to Duo-Aire drawings or U.L. information label on hood for proper FPM and CFM requirements.
3. Adjust speed of blower to obtain proper air velocities and CFM through Make-up air outlet(s).

## FINAL AIR BALANCE

### MAKE-UP AIR HOODS

1. Close all doors and windows.
2. Operate all exhaust fans, supply fans, make-up air unit and building HVAC system.
3. Turn on all cooking equipment under the hood and preheat to operating temperature.
4. Produce large quantities of smoke or steam.
5. Observe capture of vapors.
6. If all vapors are not totally captured, fine tune the system by adjusting the air volume control damper installed in the supply collar. Slightly reduce the amount of supply air directed under the hood until full capture is obtained.
7. Check total pressure in building. Pressure should not exceed .02 negative pressure.

# AIR BALANCE REPORT

## EXHAUST FANS

Fan No.	Designed RPM	Actual RPM	Designed CFM	Actual CFM
1				
2				
3				
4				
5				
			Total Exhaust	

## SUPPLY FANS

Fan No.	Designed RPM	Actual RPM	Designed CFM	Actual CFM
1				
2				
3				
4				
			Total Supply	

## HVAC SYSTEM

Unit No.	Designed RPM	Actual RPM	Designed CFM	Actual CFM	Outside Air CFM
1					
2					
3					
					Total Outside Air

# NOTES AND WORKSHEET

